



**Chassis**

- 114SD Freightliner (2020 Model Year)
- Seating Capacity - 2
- DD13 450HP Engine / 1650 LB/FT Torque
- 4000EVS 5-Spd Transmission
- Jacobs Compression Brake
  - Front: 18,000
  - Rear: 44,000
- Differential Lock on Both Rear Tandem Axles
- 230" Wheelbase
- Polished Aluminum Alcoa Wheels
- Commercial AC

**Pump & Plumbing**

- Waterous CS 1250 GPM Pump
- Trident AirPrime - Manual
- Class 1 TPG Pressure Governor
- Preconnects: (1) 1-3/4" & (1) 2-1/2"
- 2" Tank Fill
- (2) 2-1/2" Driver Side Discharges
- (1) 2-1/2" Officer Side Discharge
- (1) 5" Storz LDH Officer Side Discharge
- (1) 2-1/2" Aux Suction Inlet
- (2) 6" Non-Gated Suction Inlets

**Body**

- 3000 Gallon APR Tank
- (1) 10" Electric Newton Dump w/90 Degree Swivel
- (2) 2-1/2" Rear Direct Tank Fills
- 304 Stainless Steel Body & Sub-Frame w/30 Year Warranty
- Vibra-Torq Mounting System
- ROM Series IV Roll-Up Doors
- Front (2) 60" W x 37-1/2" H x 25-1/2" D Compartments
- Rear (2) 30" W x 37-1/2" H x 25-1/2" D Compartments
- #4 Brushed Interior Compartment Finish
- Zico 3000 Gal Hydraulic Porta-Tank Rack
- Hard Hose Storage
- ROM LED Compartment Lighting
- Whelen M6 Series LED Lighting Package W/Justice Light Bar
- (6) M9 Series LED Scene Lights



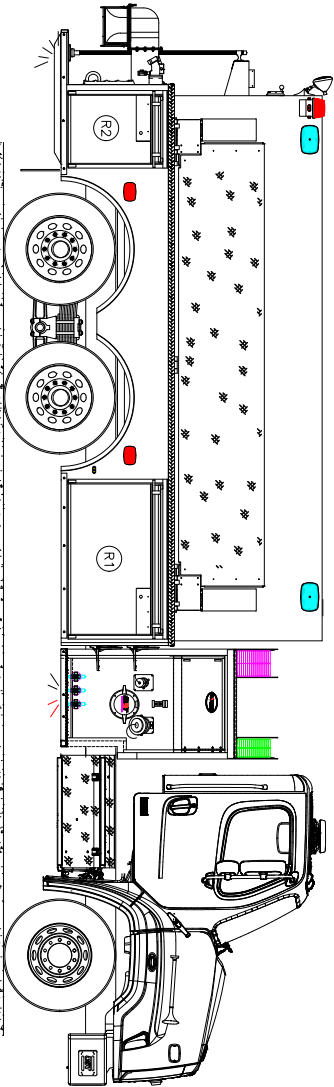
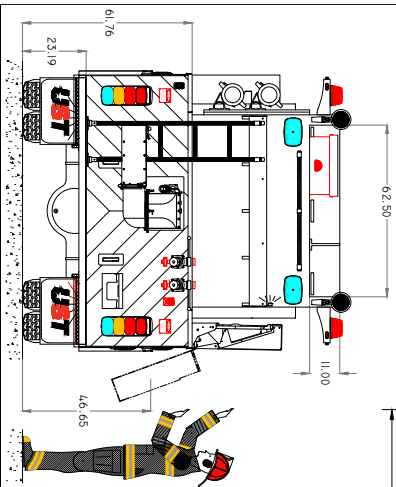
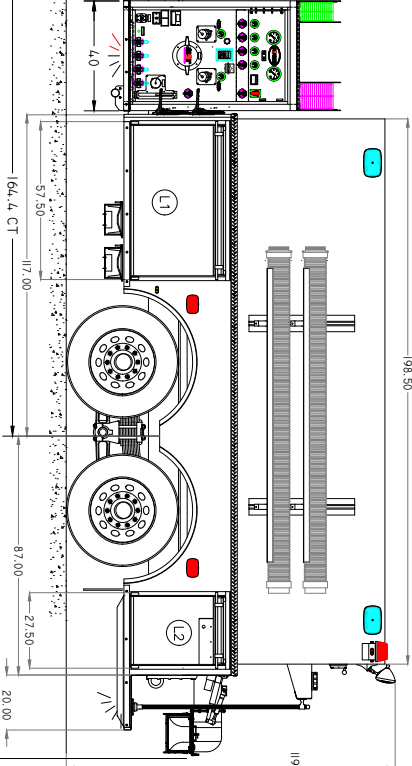
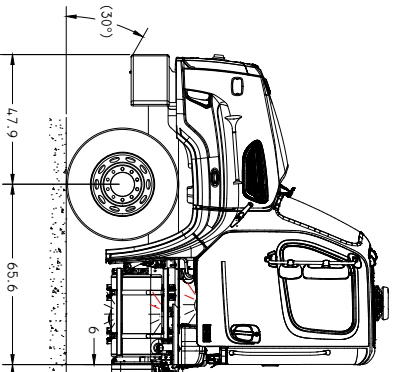
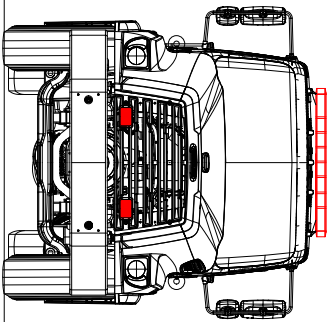
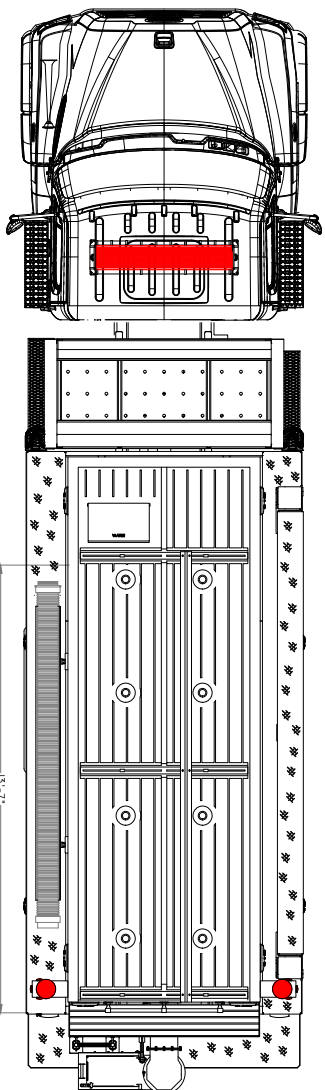

**CHASSIS:** FREIGHTLINER SBA 114SD  
**ENGINE:** DETROIT DD15 450HP  
**TRANSMISSION:** ALLISON 4000 EVS  
**AXLES:** 18,000# FRONT / 44,000# REAR  
**MODEL:** HERITAGE FDIC TANKER DEMO  
**MATERIAL/QTY:** 3000 / - GALLONS  
**PUMP:** WATERIOUS CS 1250GPM  
**FOAM SYSTEM:** -  
**GENERATOR:** -

DOOR FRAMED OPENINGS	
COMPARTMENT	DOOR FRAMED OPENING
L1	57.5"W x 84.0"H
L2	57.5"W x 84.0"H
R1	57.5"W x 84.0"H
R2	27.5"W x 84.0"H

SPECIAL NOTES:

**CUSTOMER:**  
 THIS DRAWING IS A CLOSE APPROXIMATION OF YOUR FIRE APPARATUS. IN ALL CASES WHERE THE DRAWING AND THE PHOTO DO NOT MATCH, THE PHOTO SHALL TAKE PRECEDENCE. PLEASE WORK WITH YOUR DEALER TO ASSURE THAT THE WRITTEN SPECIFICATION REPRESENTS WHAT YOU WANT IN YOUR FINISHED PRODUCT. SPARTAN MOTORS USA, INC. BUILDS TO THE WRITTEN SPECIFICATION. DRAWINGS ARE NET. ASSURE THAT YOUR NEEDS ARE MET.

**PROPRIETARY AND CONFIDENTIAL**  
 THE INFORMATION CONTAINED HEREIN IS THE SOLE PROPERTY OF SPARTAN EMERGENCY RESPONSE. ANY REPRODUCTION IN PART OR AS A WHOLE WITHOUT THE WRITTEN PERMISSION OF SPARTAN EMERGENCY RESPONSE IS PROHIBITED.

REV	DATE	ENG REVIEW	DESCRIPTION	DATE	BY
000	02/25/18				
001	02/25/18				

**CUSTOMER:** 2019 FDIC DEMO  
**TRUCK NUMBER:** U218109  
**DEALER:**