

Chassis

- Spartan Metro Star MFD 10" Raised Roof
- Cummins X12 500 HP
- Seating Capacity: 5
- Allison 4000 EVS Transmission
- Front: 20,000 lbs. Rear: 27,000 lbs.
- Independent Front Suspension
- 24" Front Bumper Extension
- 181" Wheelbase
- VMux Electrical System
- Advanced Protection System
- Advanced Climate Control
- Severe Duty Interior
- H.O. Bostrom Seats
- 65 Gallon Fuel Tank
- Two Round Grover Air Horns
- 360 Amp Niehoff Alternator
- Double Frame
- Michelin Tires

Pump and Plumbing

- Waterous CSU 2250 GPM Pump
- Trident Air Primer
- FRC InControl Pressure Governor
- 750 Gallon Poly Water Tank
- 20 Gallon Foam Cell
- Future Foam System Capable
- (1) 6" Left Side Inlet
- (1) 6" Right Side Inlet
- (1) 5" Front Bumper Suction
- (1) 2.5" Left Side Inlet
- (2) 2.5" Left Side Discharge
- (1) 2.5" Right Side Discharge
- (1) 3.5" Right Side Discharge w/4" Storz
- (1) 2.5" Left Rear Discharge
- (2) 1.75" Speedlays with removable trays
- (1) 2.5" Speedlay with removable tray
- (1) 2" Front Bumper Discharge
- (1) 3" Deck Gun
- TFT Telescoping Waterway
- Washdown System

Body

- Formed Aluminum Body
- Vibra-Torque Body Mounting System
- ROM Series IV Roll-up Doors
- Full Height/ Split Depth Compartments
- Right Side Internal Ladder Storage
- Duo Safety Ladders: (1) 24 ft. 2-section, (1) 14 ft. roof, (1) 10 ft. attic)
- Duo Safety Pike Pole Storage: (1) 12 ft., (1) 10 ft.
- Enclosed storage for two Hard Hose
- Left Side Rescue Storage for (2) backboards and (1) stokes basket
- Wheel Well SCBA and Floor Dry Storage
- Durable Compartment Finish
- LED Compartment Lighting
- Whelen LED Lighting Package

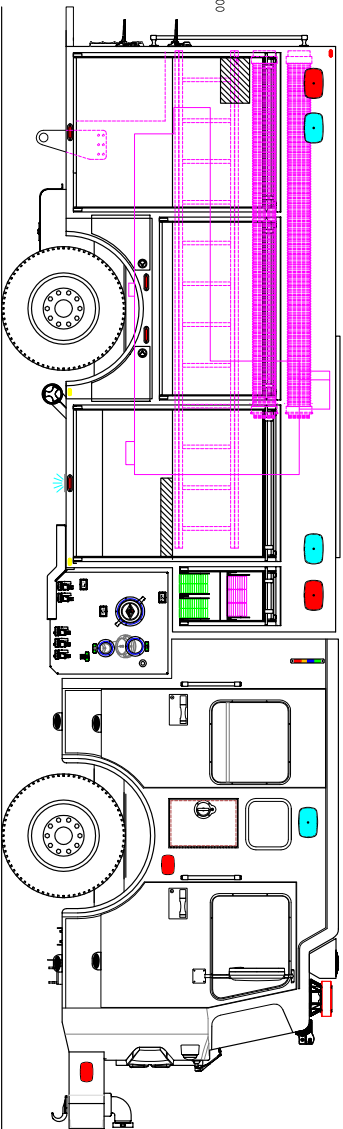
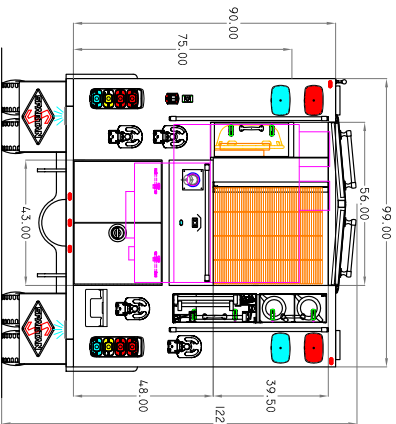
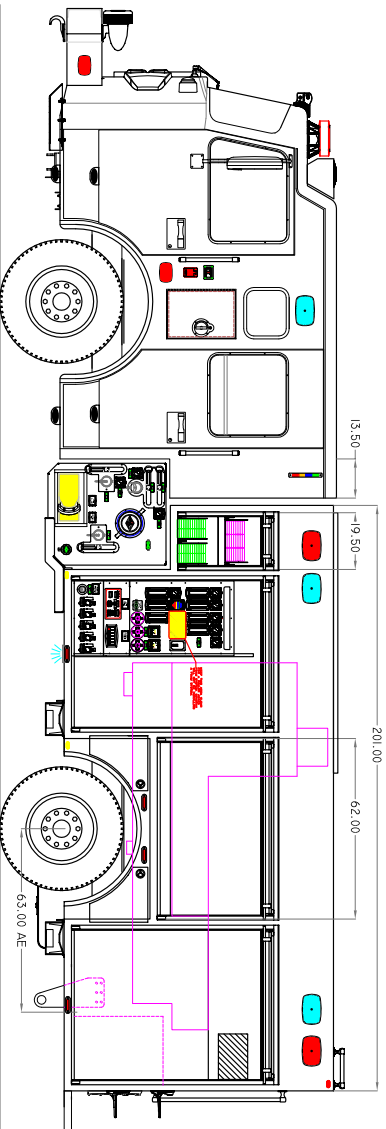
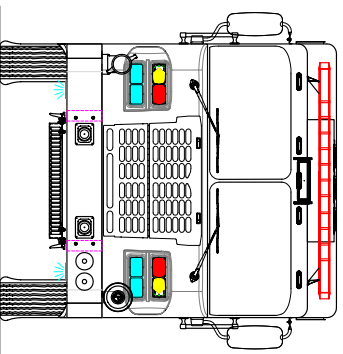
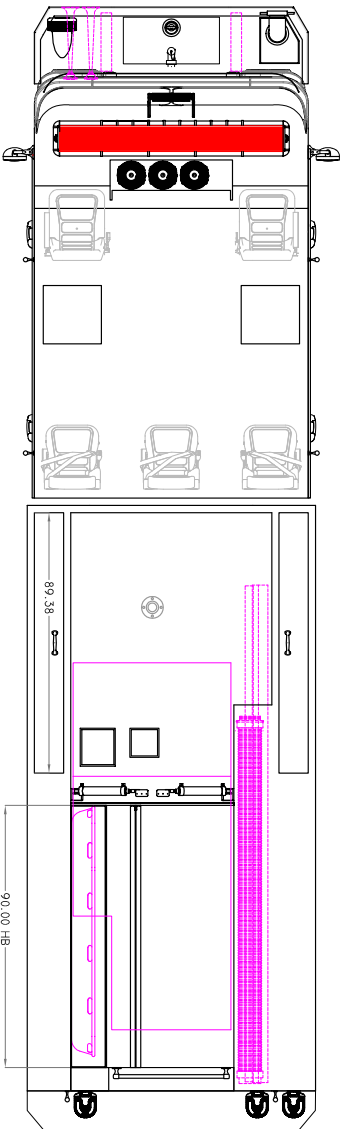

CHASSIS: SPARTAN METRO STAR MFD IORR

ENGINE: CUMMINS X12 500HP

TRANSMISSION: ALLISON 4000 EVS

AXLES: 20,000# FRONT / 27,000# REAR

MODEL: STAR PUMPER

WATER/FOAM: 750 / 20 GALLONS

PUMP: WATERFOUS CSU 2250GPM

FOAM SYSTEM: F.OAM READY

GENERATOR:

DOOR FRAMED OPENINGS

COMPARTMENT	DOG FRAMED OPENING
L1	53.0-W x 70.0-H
L2	62.0-W x 4.0-5-H
L5	54.0-W x 70.0-H
R1	53.0-W x 70.0-H
R2	62.0-W x 4.0-5-H
R3	54.0-W x 70.0-H
BI	4.5-0-W x 31.5-H

SPECIAL NOTES:

CUSTOMER

THIS DRAWING IS A CLOSE APPROXIMATION OF YOUR FIRE RESOURCES. IT IS THE CUSTOMER'S RESPONSIBILITY TO VERIFY THE ACCURACY OF ALL INFORMATION PROVIDED TO SPARTAN. SPARTAN SHALL NOT BE RESPONSIBLE FOR ANY ERRORS OR OMISSIONS. THE WRITTEN SPECIFICATION REPRESENTS WHAT YOU WANT IN YOUR FINISHED PRODUCT. SPARTAN ENGINEERING RESPONSE SHALL BE RESPONSIBLE FOR THE DESIGN AND CONSTRUCTION TO ASSURE THAT YOUR NEEDS ARE MET.

PROPRIETARY AND CONFIDENTIAL

THE INFORMATION CONTAINED IN THIS DRAWING IS THE SOLE PROPERTY OF SPARTAN EMERGENCY RESPONSE. ANY REPRODUCTION OR TRANSMISSION OF THIS INFORMATION WITHOUT THE WRITTEN PERMISSION OF SPARTAN EMERGENCY RESPONSE IS PROHIBITED. SPARTAN MOTORS USA, INC. DBA SPARTAN EMERGENCY RESPONSE.

REV.	DATE	DESCRIPTION	NAME
2	08/28/19	ENGINEERING REVIEW	DG/DND/MS
1	06/22/19	PRECON REVIEW	DJ/DD/HH
0	05/16/19	INITIAL PROPOSAL	K/S

SCALE: NOT TO SCALE

CUSTOMER: MIDWEST REGION DEMO

TRUCK NUMBER: 219093

DEALER: