

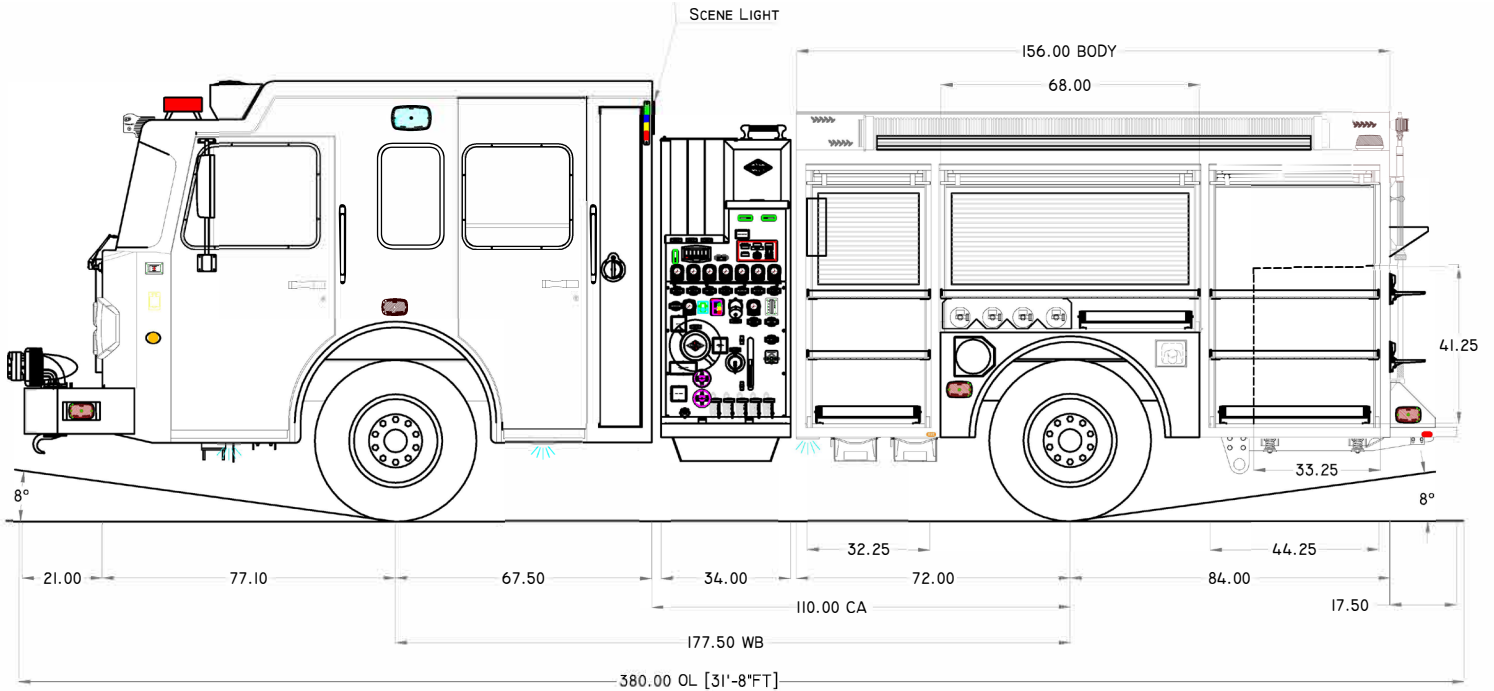

S-180 PUMPER MODEL 2107



Chassis

- Spartan MetroStar LFD 10" Raised Roof
- Seating Capacity: 6
- Cummins ISL 450 HP
- Allison 3000 EVS Transmission
- Extreme Duty Interior
- Occupant Advanced Protection System
- Front: 20,000 lbs. Rear: 27,000 lbs.
- 21" Front Bumper Extension
- 177.5" Wheelbase

Pump and Plumbing

- Hale DSD 1500 GPM Pump
- FRC InControl 400 Pressure Governor
- 750 Gallon Tank Capacity
- (1) 2.5" Left Side Auxiliary Inlet
- (1) 2.5" Right Side Auxiliary Inlet
- (1) 2.5" Left Side Discharge
- (1) 2.5" Right Side Discharge
- (1) 3" Right Side Discharge
- (1) 2.5" Right Rear Discharge
- (1) 3" Deck Gun Discharge
- (2) 1.75" Crosslays & (1) 2.5" Crosslay
- Front Bumper Discharge
- (1) 2" Tank Fill

Body

- 156" Formed Aluminum Body
- Vibra-Torque Body Mounting System
- ROM Roll-up Doors
- Full Height w/ Split Depth Compartments/ Ladders Right
- Left Side Overwheel Roll Out Drawer
- Right Side Overwheel SCBA Storage
- Durable Compartment Finish
- LED Compartment Lighting
- Whelen LED Lighting Package
- Whelen PCP2 Side Scene Lights

| Compartment | Volume (Cubic Feet) |
|---------------|---------------------|
| L1 | 40,896 |
| L2 | 48,088 |
| L3 | 50,645 |
| R1 | 29,392 |
| R2 | 27,369 |
| R3 | 36,401 |
| B1 | 31,162 |
| Hose Bed Area | 75,185 |

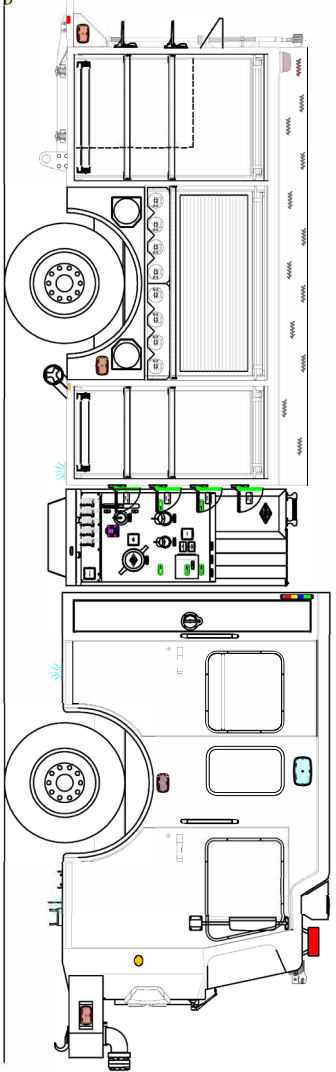
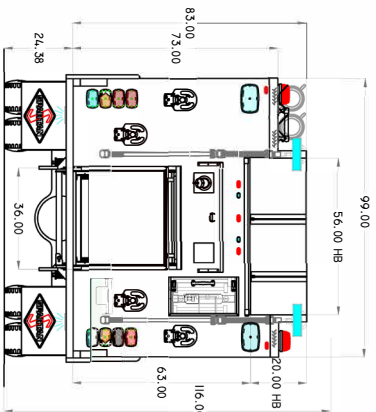
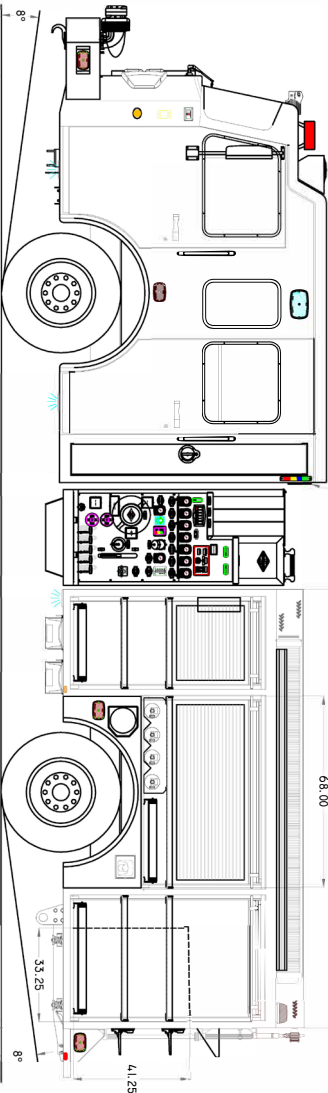
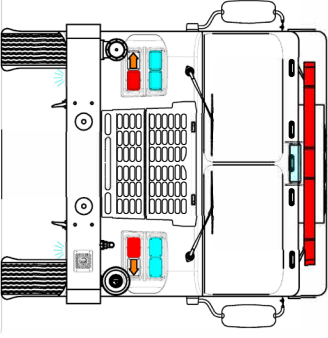
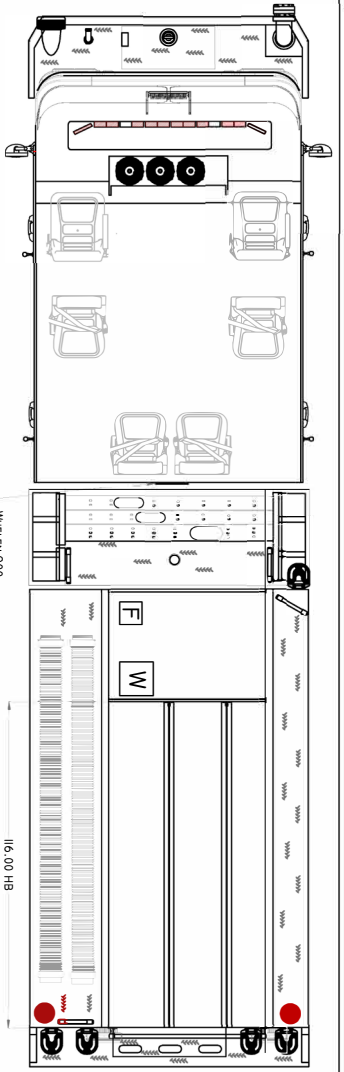

CHASSIS: SPARTAN METRO STAIR LFD 10' RR
 ENGINE: CUMMINS L9 450 HP
 TRANSMISSION: ALLISON 3000 EUS
 AXLES: F 20,000 LB / R 27,000 LB

MODEL: 2107
 WATER/FOAM: 750 GALLONS / 20 GALLONS

PUMP: HALE DSD 1500 GPM

FOAM SYSTEM: N/A

GENERATOR: N/A

| DOOR FRAMED OPENINGS | |
|----------------------|---------------------|
| COMPARTMENT | DOOR FRAMED OPENING |
| L1 | 32.25-W X 68.0-H |
| L2 | 68.0-W X 43.0-H |
| L3 | 44.25-W X 68.0-H |
| R1 | 32.25-W X 68.0-H |
| R2 | 68.0-W X 43.0-H |
| R3 | 44.25-W X 68.0-H |
| B1 | 36.0-W X 57.25-H |

SPECIAL NOTES:

- LADDER PACKAGE**
 (1) DUC-SAFETY 26 FT 2-SEC. 900A
 (1) DUC-SAFETY 16 FT. ROOF 775A
 (1) DUC-SAFETY 18 FT. ATTC. 585A
- STORAGE FOR**
 (2) Pail Hooks with Straps
 (1) Assoc. Tackle Hook, up to 10FT LANK

CUSTOMER
 THIS DRAWING IS A CLOSE APPROXIMATION OF YOUR FIRE WRITTEN SPECIFICATION. THE SPECIFICATION DIFFERS FROM THE WRITTEN SPECIFICATION. PLEASE WORK WITH YOUR DEALER TO ASSURE THAT THE WRITTEN SPECIFICATION REPRESENTS WHAT YOU WANT IN BUILDS TO THE WRITTEN SPECIFICATION, NOT THE DRAWING TO ASSURE THAT YOUR NEEDS ARE MET.

PROPRIETARY AND CONFIDENTIAL
 THE INFORMATION CONTAINED IN THIS DRAWING IS THE SOLE PROPERTY OF SPARTAN EMERGENCY RESPONSE. ANY REPRODUCTION OR TRANSMISSION OF THIS INFORMATION WITHOUT THE WRITTEN PERMISSION OF SPARTAN EMERGENCY RESPONSE IS PROHIBITED. SPARTAN VEHICLES SALES INC. DBA SPARTAN EMERGENCY SERVICES, TROY, MI.

| REV | DATE | DESCRIPTION | NAME |
|-----|----------|-----------------------|--------|
| 2 | 11/2/18 | ENG UPDATES-MIGRATION | SS/SD |
| 1 | 5/11/17 | CHANGES FROM VARIKUP | W.C. |
| 0 | 03/24/16 | INITIAL PROPOSAL | M.G.H. |

SCALE: NOT TO SCALE
 TRUCK NUMBER: MODEL 2107-08
 DEALER: