

S-180 CUSTOM AERIAL

MODEL #RMP100

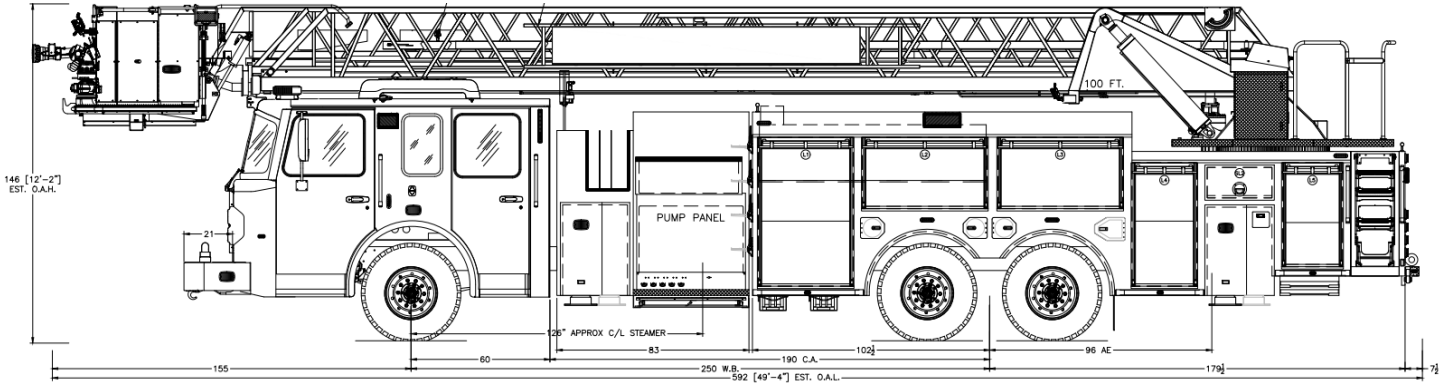

CHASSIS

- Spartan Gladiator EMFD Flat Roof
- Seating Capacity 6
- Cummins X15 565 HP Engine
- Allison 4000 EVS Transmission
- Extreme Duty Interior
- Advanced Protection System®
- Steertek™ NXT Front Suspension
- Firemaax™ Rear Suspension
- Axles: 23,000 Front, 62,000 Rear
- 21" Front Bumper Extension
- 250" Wheelbase
- Advanced Climate Control
- Rear View Backup Camera
- Side Scene Lighting
- 45° Cramp Angle
- Michelin Tires
- Severe Duty Front Bumper
- Dual Grover Brand Stutter Air Horns
- Federal Q2B Mechanical Siren

PUMP & PLUMBING

- Waterous CSU 2000 GPM
- FRC InControl Pressure Governor
- 400 Gallons Water / 20 Gallons Foam
- Pre-Connects:
 - (2) 1-3/4" Crosslays
 - (1) 2-1/2" Crosslay
 - (1) 2-1/2" Front Bumper Discharge
- Poly Water Tank

AERIAL & WATERWAY

- 1250lb Tip Load Dry / 500lb Wet
- Four H-Style Outriggers Behind Cab and Behind Rear Axle w/ 18' Jack Spread
- 100' Vertical Reach, 98' Horizontal Reach
- 72° Max Elevation, -12° Min Elevation
- 12'-2" (146") Overall Height
- 5" Waterway Inlet Curbside
- Whelen Scene Lighting at Tip and Base
- TFT Flex RC 2000 GPM Electric Monitor
- TFT Valve Under Monitor w/ 2-1/2" Gated Elbow
- Storage for 14' Roof Ladder in Base Section
- Storage for 8' Pike Pole in Fly Section

BODY

- High Strength Aluminum Body
- Vibra-Torque Body Mounting System
- ROM Series IV Roll-up Doors
- Door Protection Shields
- SCBA Bottle Storage for (8)
- Durable Compartment Finish
- OnScene LED Compartment Lighting
- Whelen LED Lighting Package
- 136' Ladder Storage for 35', 28', 16', 10' Attic Ladder, 17' Little Giant, Three Pike Poles, Two D-handle Pike Poles, and Three NY Roof Hook
- Whelen Pioneer Side Scene Lighting
- Optional 6kW Generator
- Rear Directional Light
- 40 Cubic Feet Hose Bed Volume
- Folding Turntable Access Ladder LH Side

- 12' 6"
- 11' 6"
- 11' 0"
- 10' 6"
- 10' 0"
- 9' 6"
- 9' 0"
- 8' 6"
- 8' 0"
- 7' 6"
- 7' 0"
- 6' 6"
- 6' 0"
- 5' 6"
- 5' 0"
- 4' 6"
- 4' 0"
- 3' 6"
- 3' 0"
- 2' 6"
- 2' 0"
- 1' 6"
- 6"

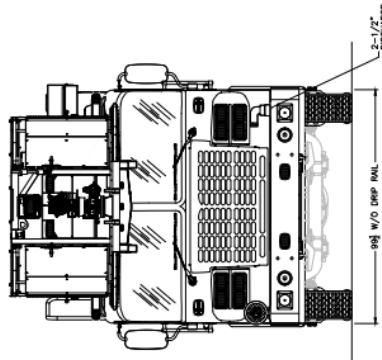
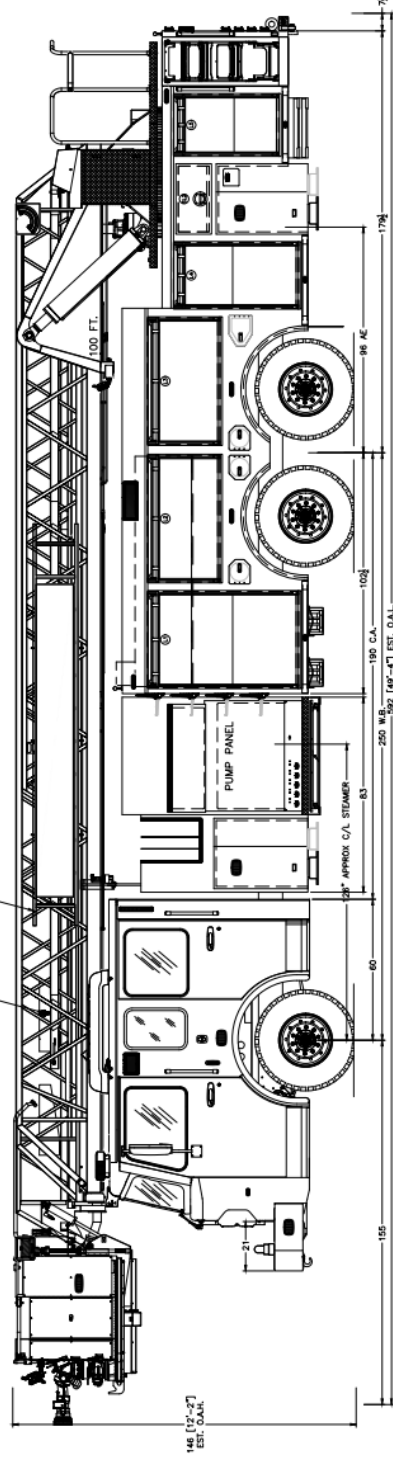
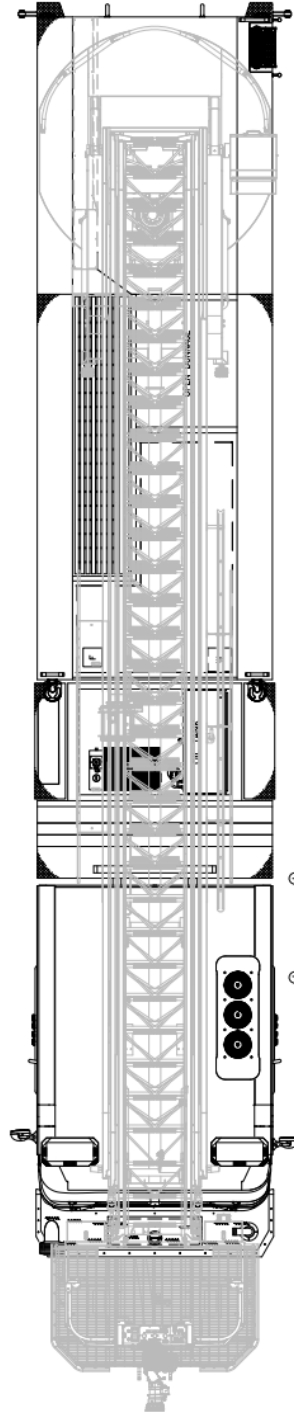
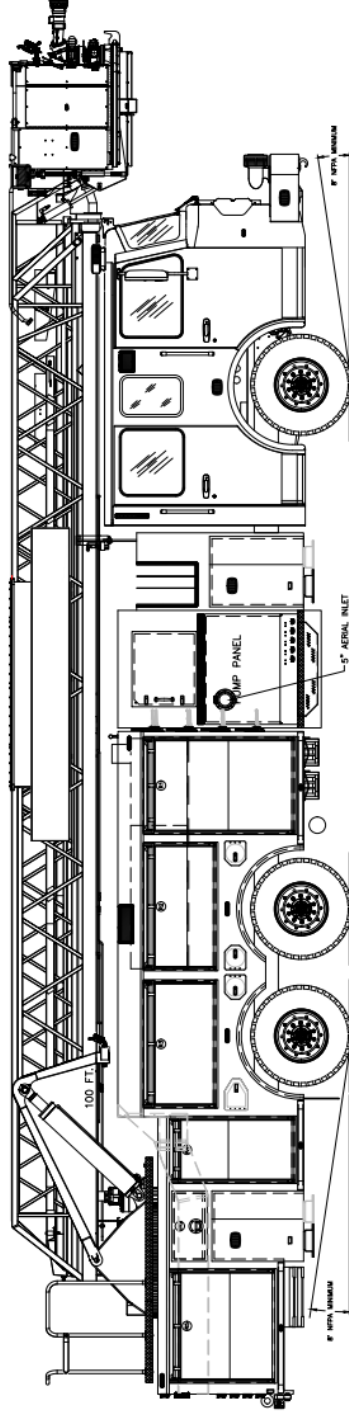

COMPONENT	DESCRIPTION	QUANTITY	UNIT	PRICE
1	AMBULANCE	1	UNIT	10000
2	STRETCHER	1	UNIT	1500
3	WHEELS	4	PAIRS	200
4	AXLES	2	PAIRS	100
5	ENGINE	1	UNIT	1200
6	TRANSMISSION	1	UNIT	800
7	DRIVE SHAFT	1	UNIT	150
8	DIFFERENTIAL	2	PAIRS	100
9	STEERING	1	UNIT	100
10	WHEELS	4	PAIRS	200
11	AXLES	2	PAIRS	100
12	ENGINE	1	UNIT	1200
13	TRANSMISSION	1	UNIT	800
14	DRIVE SHAFT	1	UNIT	150
15	DIFFERENTIAL	2	PAIRS	100
16	STEERING	1	UNIT	100
17	WHEELS	4	PAIRS	200
18	AXLES	2	PAIRS	100
19	ENGINE	1	UNIT	1200
20	TRANSMISSION	1	UNIT	800
21	DRIVE SHAFT	1	UNIT	150
22	DIFFERENTIAL	2	PAIRS	100
23	STEERING	1	UNIT	100
24	WHEELS	4	PAIRS	200
25	AXLES	2	PAIRS	100
26	ENGINE	1	UNIT	1200
27	TRANSMISSION	1	UNIT	800
28	DRIVE SHAFT	1	UNIT	150
29	DIFFERENTIAL	2	PAIRS	100
30	STEERING	1	UNIT	100
31	WHEELS	4	PAIRS	200
32	AXLES	2	PAIRS	100
33	ENGINE	1	UNIT	1200
34	TRANSMISSION	1	UNIT	800
35	DRIVE SHAFT	1	UNIT	150
36	DIFFERENTIAL	2	PAIRS	100
37	STEERING	1	UNIT	100
38	WHEELS	4	PAIRS	200
39	AXLES	2	PAIRS	100
40	ENGINE	1	UNIT	1200
41	TRANSMISSION	1	UNIT	800
42	DRIVE SHAFT	1	UNIT	150
43	DIFFERENTIAL	2	PAIRS	100
44	STEERING	1	UNIT	100
45	WHEELS	4	PAIRS	200
46	AXLES	2	PAIRS	100
47	ENGINE	1	UNIT	1200
48	TRANSMISSION	1	UNIT	800
49	DRIVE SHAFT	1	UNIT	150
50	DIFFERENTIAL	2	PAIRS	100
51	STEERING	1	UNIT	100
52	WHEELS	4	PAIRS	200
53	AXLES	2	PAIRS	100
54	ENGINE	1	UNIT	1200
55	TRANSMISSION	1	UNIT	800
56	DRIVE SHAFT	1	UNIT	150
57	DIFFERENTIAL	2	PAIRS	100
58	STEERING	1	UNIT	100
59	WHEELS	4	PAIRS	200
60	AXLES	2	PAIRS	100
61	ENGINE	1	UNIT	1200
62	TRANSMISSION	1	UNIT	800
63	DRIVE SHAFT	1	UNIT	150
64	DIFFERENTIAL	2	PAIRS	100
65	STEERING	1	UNIT	100
66	WHEELS	4	PAIRS	200
67	AXLES	2	PAIRS	100
68	ENGINE	1	UNIT	1200
69	TRANSMISSION	1	UNIT	800
70	DRIVE SHAFT	1	UNIT	150
71	DIFFERENTIAL	2	PAIRS	100
72	STEERING	1	UNIT	100
73	WHEELS	4	PAIRS	200
74	AXLES	2	PAIRS	100
75	ENGINE	1	UNIT	1200
76	TRANSMISSION	1	UNIT	800
77	DRIVE SHAFT	1	UNIT	150
78	DIFFERENTIAL	2	PAIRS	100
79	STEERING	1	UNIT	100
80	WHEELS	4	PAIRS	200
81	AXLES	2	PAIRS	100
82	ENGINE	1	UNIT	1200
83	TRANSMISSION	1	UNIT	800
84	DRIVE SHAFT	1	UNIT	150
85	DIFFERENTIAL	2	PAIRS	100
86	STEERING	1	UNIT	100
87	WHEELS	4	PAIRS	200
88	AXLES	2	PAIRS	100
89	ENGINE	1	UNIT	1200
90	TRANSMISSION	1	UNIT	800
91	DRIVE SHAFT	1	UNIT	150
92	DIFFERENTIAL	2	PAIRS	100
93	STEERING	1	UNIT	100
94	WHEELS	4	PAIRS	200
95	AXLES	2	PAIRS	100
96	ENGINE	1	UNIT	1200
97	TRANSMISSION	1	UNIT	800
98	DRIVE SHAFT	1	UNIT	150
99	DIFFERENTIAL	2	PAIRS	100
100	STEERING	1	UNIT	100

ITEM	DESCRIPTION	PRICE
1	AMBULANCE	10000
2	STRETCHER	1500
3	WHEELS	200
4	AXLES	100
5	ENGINE	1200
6	TRANSMISSION	800
7	DRIVE SHAFT	150
8	DIFFERENTIAL	100
9	STEERING	100
10	WHEELS	200
11	AXLES	100
12	ENGINE	1200
13	TRANSMISSION	800
14	DRIVE SHAFT	150
15	DIFFERENTIAL	100
16	STEERING	100
17	WHEELS	200
18	AXLES	100
19	ENGINE	1200
20	TRANSMISSION	800
21	DRIVE SHAFT	150
22	DIFFERENTIAL	100
23	STEERING	100
24	WHEELS	200
25	AXLES	100
26	ENGINE	1200
27	TRANSMISSION	800
28	DRIVE SHAFT	150
29	DIFFERENTIAL	100
30	STEERING	100
31	WHEELS	200
32	AXLES	100
33	ENGINE	1200
34	TRANSMISSION	800
35	DRIVE SHAFT	150
36	DIFFERENTIAL	100
37	STEERING	100
38	WHEELS	200
39	AXLES	100
40	ENGINE	1200
41	TRANSMISSION	800
42	DRIVE SHAFT	150
43	DIFFERENTIAL	100
44	STEERING	100
45	WHEELS	200
46	AXLES	100
47	ENGINE	1200
48	TRANSMISSION	800
49	DRIVE SHAFT	150
50	DIFFERENTIAL	100
51	STEERING	100
52	WHEELS	200
53	AXLES	100
54	ENGINE	1200
55	TRANSMISSION	800
56	DRIVE SHAFT	150
57	DIFFERENTIAL	100
58	STEERING	100
59	WHEELS	200
60	AXLES	100
61	ENGINE	1200
62	TRANSMISSION	800
63	DRIVE SHAFT	150
64	DIFFERENTIAL	100
65	STEERING	100
66	WHEELS	200
67	AXLES	100
68	ENGINE	1200
69	TRANSMISSION	800
70	DRIVE SHAFT	150
71	DIFFERENTIAL	100
72	STEERING	100
73	WHEELS	200
74	AXLES	100
75	ENGINE	1200
76	TRANSMISSION	800
77	DRIVE SHAFT	150
78	DIFFERENTIAL	100
79	STEERING	100
80	WHEELS	200
81	AXLES	100
82	ENGINE	1200
83	TRANSMISSION	800
84	DRIVE SHAFT	150
85	DIFFERENTIAL	100
86	STEERING	100
87	WHEELS	200
88	AXLES	100
89	ENGINE	1200
90	TRANSMISSION	800
91	DRIVE SHAFT	150
92	DIFFERENTIAL	100
93	STEERING	100
94	WHEELS	200
95	AXLES	100
96	ENGINE	1200
97	TRANSMISSION	800
98	DRIVE SHAFT	150
99	DIFFERENTIAL	100
100	STEERING	100

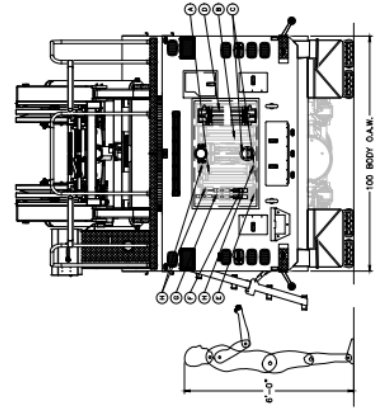

PUTTING FIRST RESPONDERS FIRST.

spartaner.com/s-180