

# S-180 CUSTOM PUMPER

MODEL #4117

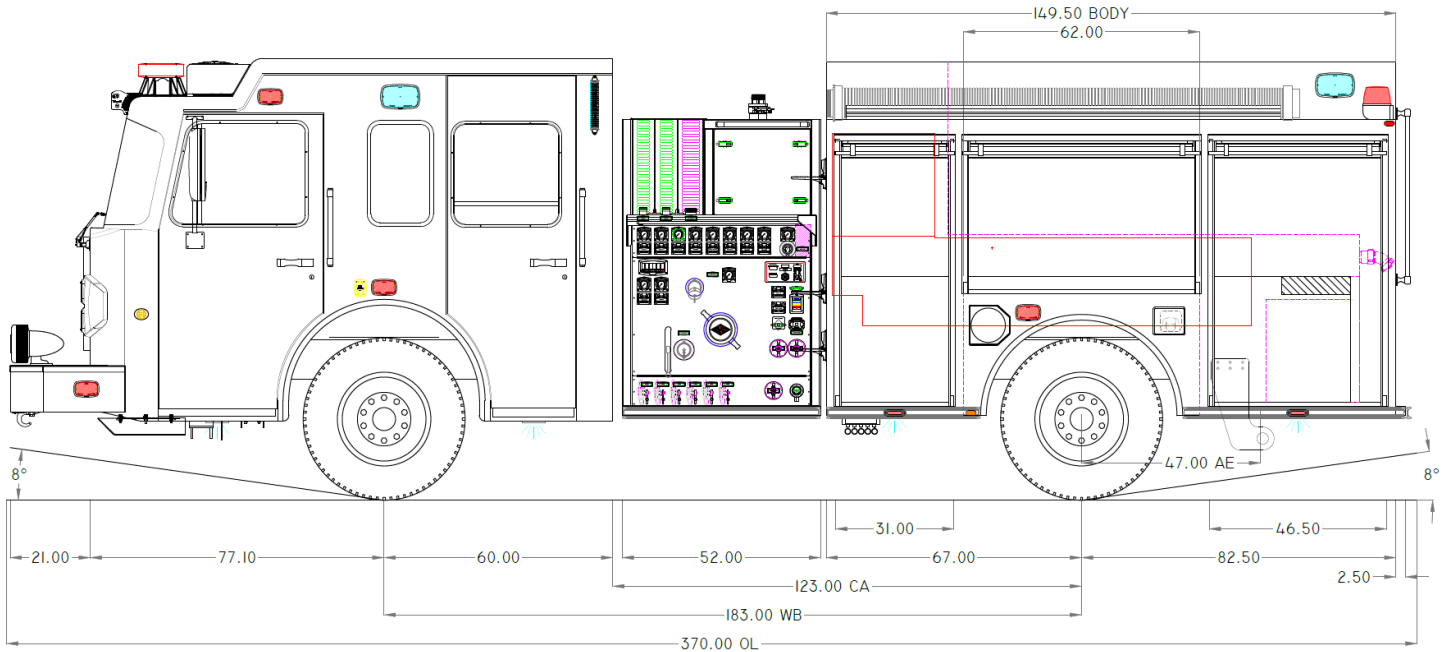

## ROAD READY IN 12 MONTHS OR LESS\*

### CHASSIS

- Spartan Metro Star EMFD 10" Raised Roof
- Seating Capacity 6
- Cummins X10 450HP MHD or HHD Engine
- Extreme Duty Interior
- FRC OmniPlex 10" Touchscreen Controls
- 12.8" Touchscreen Instrument Cluster
- IMMI 4Front® & RollTek™ Occupant Protection
- Independent Front Suspension
- Axles: 21,500 Front, 24,000 Rear
- 21" Front Bumper Extension
- 183" Wheelbase
- Advanced Climate Control
- Rear View Backup Camera w/ Color Display
- Whelen Front & Side Scene Lighting
- 48° Cramp Angle
- Michelin Tires
- HD Steel Severe Duty Front Bumper
- Dual Grover Brand Stutter Air Horns
- Optional Federal Q2B Mechanical Siren

### BEST IN CLASS FEATURES

- 2-year bumper-to-bumper warranty, backed by Spartan's nationwide service and support network
- Features non-proprietary pump components and standard parts, making reordering easy and efficient

### PUMP & PLUMBING

- Waterous CSU 2000 GPM
- FRC InControl Pressure Governor
- 500 Gallons Water / 20 Gallons Foam
- 5" Front Suction w/ Swivel
- 4" Master Discharge
- Booster Reel
- LH and RH Rear Discharges
- Pre-Connects:
  - (2) 1-3/4" Crosslays
  - (1) 2-1/2" Crosslay
  - (1) 2-1/2" Front Trashline
  - (1) 2-1/2" Hose Bed
- TFT Extenda-Gun on Deluge Riser
- Poly Water Tank

### BODY

- Tri-Max™ High Strength Aluminum Body
- High/Low Configuration with Low Hosebed
- Vibra-Torque Body Mounting System
- ROM Series IV Roll-up Doors
- Dual Full-Height LED Compartment Lights
- Door Protection Shields
- SCBA Bottle Storage for (3)
- Durable Compartment Finish
- OnScene LED Compartment Lighting
- Whelen LED Lighting Package
- Side Mounted 24', 14', 10' Attic Ladder, and Two std Pike Poles
- Intermediate Rear Step w/ Handhold
- Whelen Side Scene Lighting

\*Subject to availability and order intake  
©2026 Terex Corporation. All Rights Reserved.

[spartaner.com/s-180-Quicker-Delivery/](https://spartaner.com/s-180-Quicker-Delivery/)

\*\*\* OPTIONAL CONTENT NOT SHOWN \*\*\*  
REFER TO QUOTEWRITER SPECIFICATIONS  
FOR FULL OPTION CONTENT

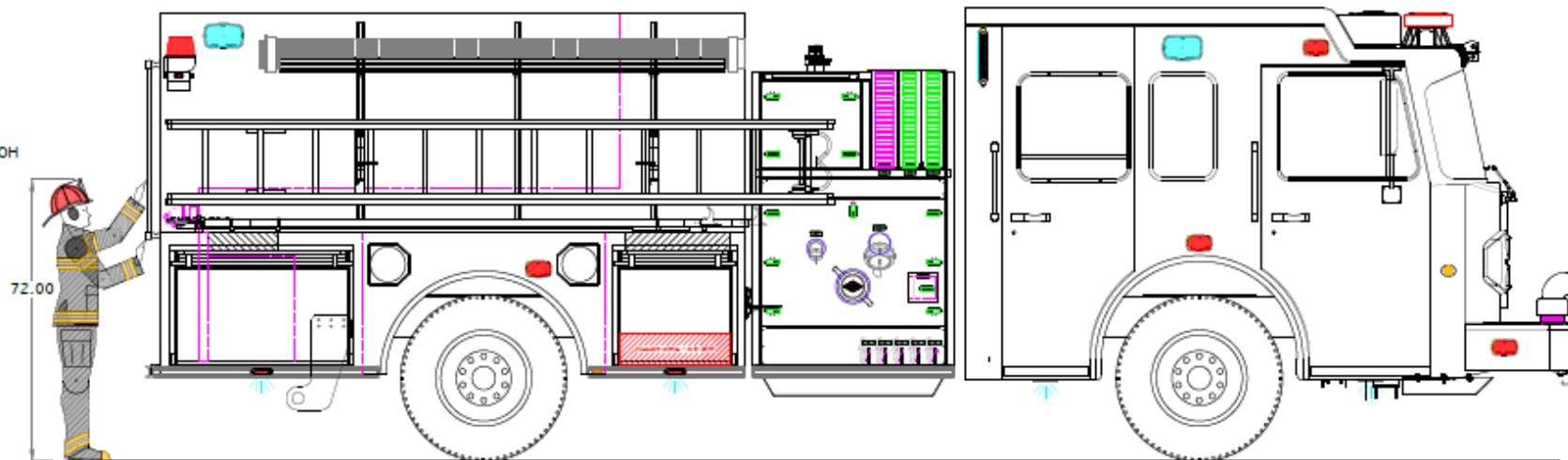
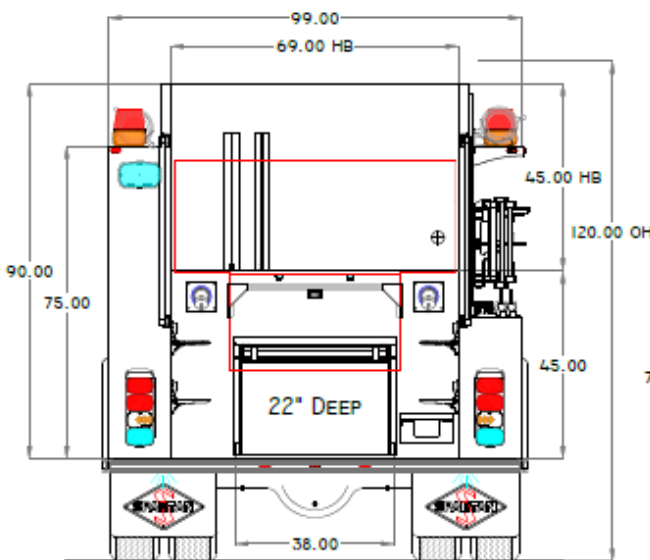
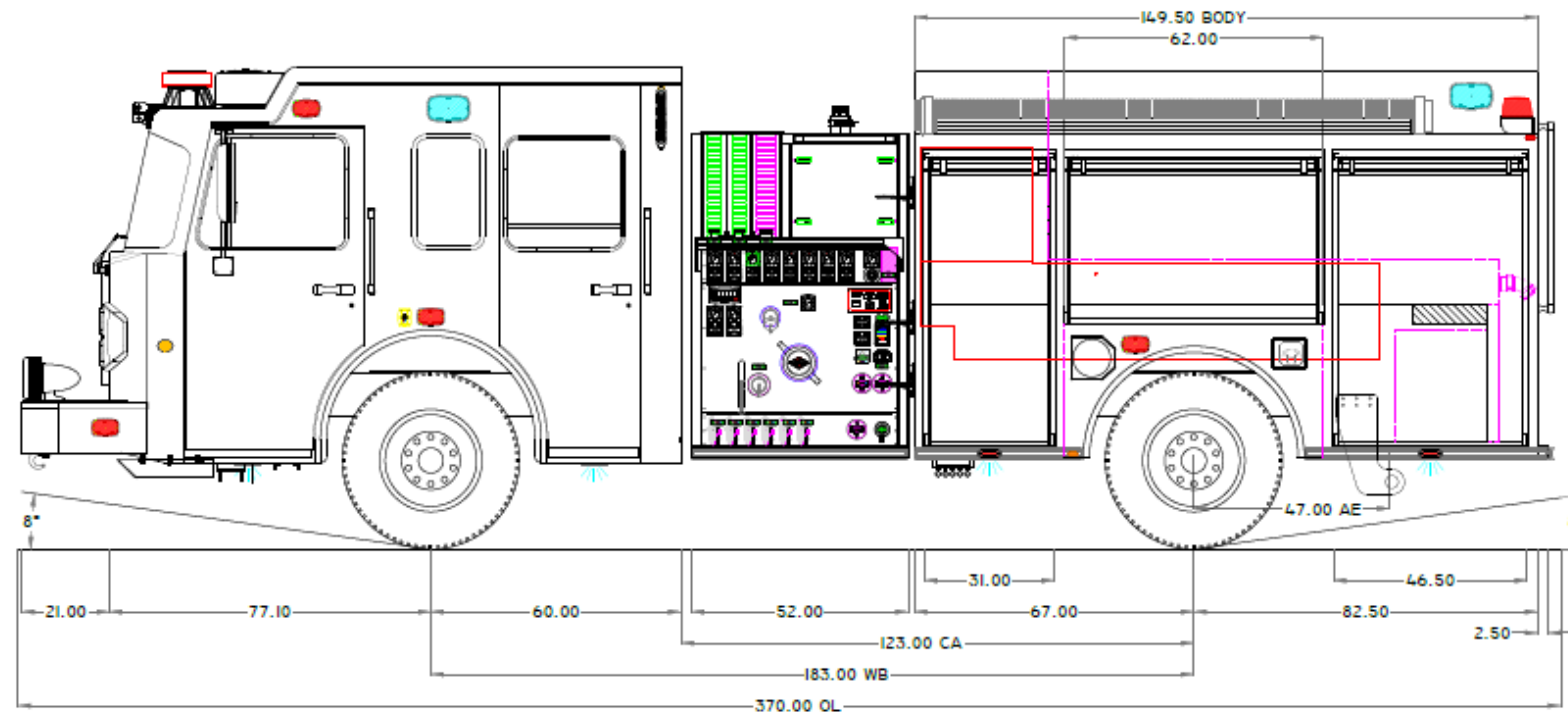
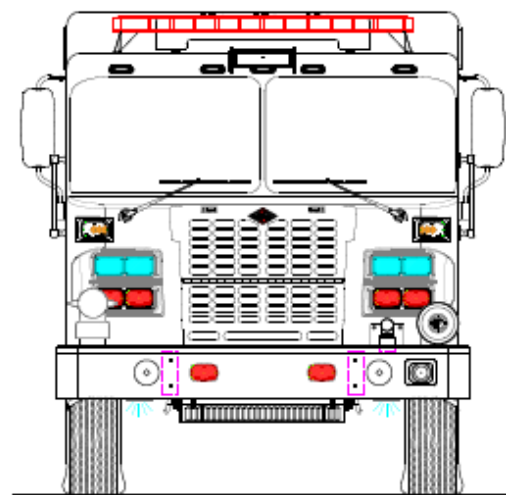
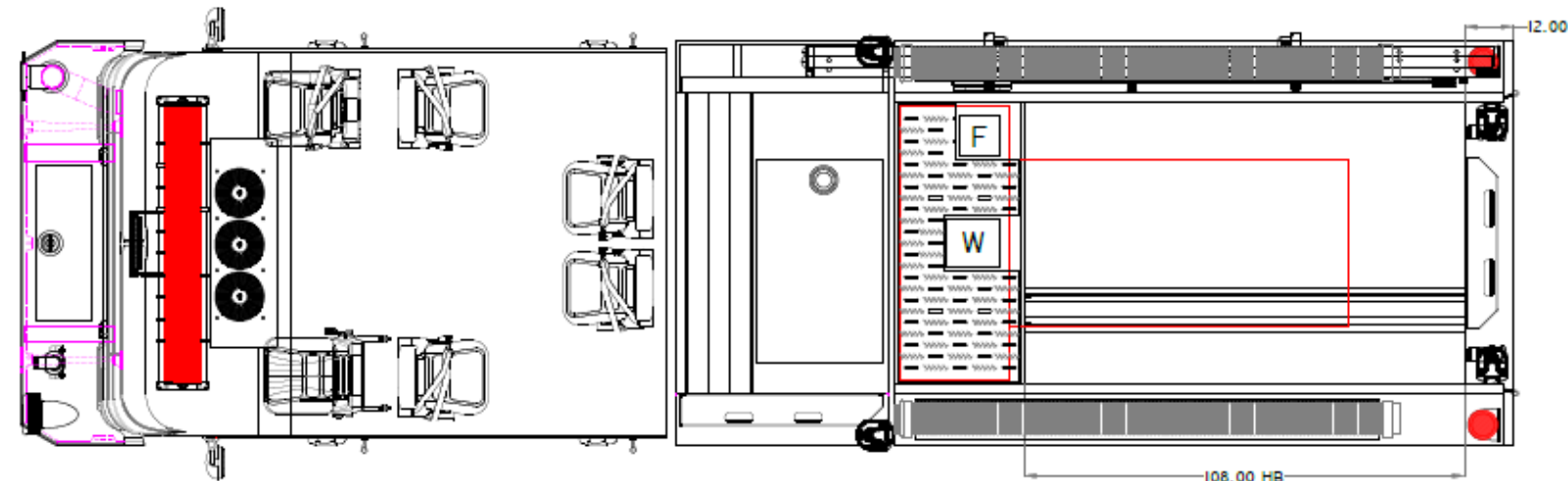

**EMERGENCY RESPONSE**

CHASSIS:	SPARTAN METRO STAR EMFD 10" RR
ENGINE:	CUMMINS X10 MD
TRANSMISSION:	ALLISON 3000 EVS
AXLES:	21,500# FRONT / 21,000# REAR
MODEL:	4117 STAR PUMPER
WATER/FOAM:	500 / 20 GALLONS
PUMP:	WATEROUS CSU 2000GPM
FOAM SYSTEM:	-
GENERATOR:	-

**DOOR FRAMED OPENINGS**

COMPARTMENT	DOOR FRAMED OPENING
L1	31.0-W x 70.0-H
L2	62.0-W x 40.5-H
L3	46.5-W x 70.0-H
R1	31.0-W x 29.5-H
R2	46.5-W x 29.5-H
BI	38.0-W x 27.0-H

**SPECIAL NOTES:**

**CUSTOMER**  
THIS DRAWING IS A CLOSE APPROXIMATION OF YOUR FIRE APPARATUS. IN ALL CASES WHERE THE DRAWING AND THE WRITTEN SPECIFICATION DIFFER, THE SPECIFICATION SHALL PREVAIL. PLEASE WORK WITH YOUR DEALER TO ASSURE THAT THE WRITTEN SPECIFICATION REPRESENTS WHAT YOU WANT IN YOUR FINISHED PRODUCT. SPARTAN EMERGENCY RESPONSE BUILDS TO THE WRITTEN SPECIFICATION, NOT THE DRAWING TO ASSURE THAT YOUR NEEDS ARE MET.

**PROPRIETARY AND CONFIDENTIAL**  
THE INFORMATION CONTAINED IN THIS DRAWING IS THE SOLE PROPERTY OF SPARTAN EMERGENCY RESPONSE. ANY REPRODUCTION IN PART OR AS A WHOLE WITHOUT THE WRITTEN PERMISSION OF SPARTAN EMERGENCY RESPONSE IS PROHIBITED. SPARTAN MOTORS USA, INC. D/B/A SPARTAN EMERGENCY RESPONSE.

REV	DATE	DESCRIPTION	NAME
5	02/03/26	ENGINEERING COMPLETE	JM/RGH/AN
4	01/21/26	PRECON REVIEW	JM/RGH/AN
3	11/19/25	ENGINEERING REVIEW	CCS
0	04/28/25	INITIAL PROPOSAL	B.H.

SCALE: NOT TO SCALE

CUSTOMER:

TRUCK NUMBER: MODEL 4117  
DEALER:

# S-180 CUSTOM PUMPER

## MODEL #4117



## OPTIONAL FEATURES

- Additional Hose Bed Divider**  
Provides flexibility for organized hose storage.  
QTY: \_\_\_\_\_
- Painted Roll-Up Doors**  
Match roll-up doors to your custom paint color.
- Satin Finish Roll Up Doors**  
Durable, corrosion resistant aluminum finish.
- Black-Out Package**  
Black light bezels, black wheel well trim, black anodized aluminum grab rails, and black powder coated folding steps.
- Booster Reel**  
Booster reel with electric rewind in pump upper storage for rapid deployment.
- FC-94 Chassis**  
MFD 94" Cab with 450 horsepower Cummins X10, both Medium Torque and High Torque optional. Reduces OAL by 3" and wheelbase by 6" with the same 6-person seating.
- Additional Upper Shelves**  
Organize open space for specific storage needs.  
QTY/Location: \_\_\_\_\_
- Additional Lower Shelves**  
Maximize compartment depth for flexible storage.  
QTY/Location: \_\_\_\_\_
- Floor Mounted Roll-Out Trays**  
Provide ergonomic access with heavy duty storage.  
QTY/Location: \_\_\_\_\_
- Wheel Chocks**  
Folding NFPA compliant wheel chocks stored under left side compartments.
- Hard Suction Hoses w/Carriers**  
Two anodized aluminum hose storage with restraints including clear PVC 6" x 10' installed each side.